

EKK! GET YOUR SLIMY TENTACLES OFF OF ME... YOU MASHER!

GORT! KLATU... MONEYOLA... PARKING METER, PLEASE...

# Ladies & Gentlemen, Welcome to: WINDYCON 7

STEIN

'79

"FANS WITH A PRESENCE OF MIND  
WILL VOTE NASHVILLE IN '79"



THE NASHVILLE IN '79 COMMITTEE  
KEN MOORE, CHAIRMAN



"NASHVILLE IS NEAT IN 100° HEAT"

'79

---

# WINDYCON 2

---

OCTOBER 3-5, 1975

ASCOT HOUSE

CHICAGO, ILLINOIS

Pro Guest of Honor    — BOB TUCKER  
Fan Guest of Honor    — JONI STOPA  
Toastmaster            — BOB "HAWKEYE" PASSOVOY

---

## THE COMMITTEE

Co-Chairfen            — LYNNE & MARK ARONSON  
Secretary              — PHYLLIS EISENSTEIN  
Hucksters              — RUSTY HEVELIN  
Art Show                — CAROL RESNICK  
Program                 — MIKE RESNICK  
Registration            — LYNNE ARONSON  
Films                    — NARD KORDELL  
Auction/Security        — BOB PASSOVOY  
Masquerade             — CORINNA FRANK  
Computer Games         — STEVE JOHNSON

---

Hank Beck  
Martha Beck  
Chip Bestler  
Pat Bryson  
Gale Burnick  
Ann Cass  
Lynne Christopher  
Martha Coady  
Doug Drummond  
Evelyn Drummond  
Yale Edeiken  
Alex Eisenstein  
Phil Foglio  
Al Frank  
Jackie Franke  
Jim Fuerstenberg  
Elliott Grunberg  
Linda Hosteny

Ken Konkol  
Mitch Kontek  
Marcelle Lyn  
George R.R. Martin  
Paul Marxen  
Vicki Marxen  
Dave Nesius  
Anne Passovoy  
De Peterson  
Pauline Prococy  
Larry Propp  
Doug Rice  
Sheryl Smith  
Ben Solon  
Barry Waitsman  
Chuck Waitzman  
Elsie Waitzman

---

Progress Report No. 1 cover art — Phil Foglio  
Progress Report No. 2 cover art — Jackie Franke  
Program Book Cover Art — Mike Stein  
Moose Feeding and Training — Eric Idle

**When you need  
citizens band two-way radio,  
make sure you have Cobra.**



This man is talking to one of several million other CB operators. Help will be on the way in minutes.

Without CB he'd have to rely on smoke signals. Or a passing motorist concerned enough to stop. See any?

He's using a 23-channel Cobra CB radio. Why Cobra? He asked some friends, CB'ers for years, what brand they'd buy if they wanted the best.

He's very glad he took their advice.

Since it's far more than a toy walkie-talkie, he has the required FCC license. There was just one simple form to fill out with no test needed.

Installation was easy, and now he talks to people wherever he goes to find out what traffic's like ahead, get directions, find a good place to spend the night or just pass the time of day.

And get help on a lonely road.

  
**Cobra**

Product of DYNASCAN CORPORATION  
1801 W. Belle Plaine • Chicago, Illinois 60613

**ARTHUR WILSON TUCKER  
PRO GUEST OF HONOR  
(AKA BOB TUCKER, FAN)**



Photo copyright © 1975 by Fred Haskell

The Immortal Bob Tucker, in his professional persona, is known as Arthur Wilson Tucker. He became a pro with the sale of a short story to Frederik Pohl in 1941. During his writing years (35) he has sold about 30 short stories and 21 novels. His first novel, a mystery, was written in 1945 and published in 1946. Today that story, The Chinese Doll, is a classic in that field.

His first SF novel, The City and the Sea, was published in 1951. He went on to such classics as To the Tombaugh Station, Wild Talent and The Long Loud Silence. A later book, The Year of the Quiet Sun, appeared on a Hugo ballot. Alas, a lesser talent won that year.

His most recent book (Ice and Iron, Doubleday, 1974; I have a copy, suitably inscribed) is soon to be released in paperback. Buy it; it's not only good for you but tasty, too. Arthur Wilson will happily inscribe it properly for you if you ask. If you are pretty and female, he'll be even happier to inscribe it (I don't guarantee "properly", though . . .).

Wilson Tucker is not nearly as well known as The Immortal Bob Tucker, member of First Fandom, publisher of Le Zombië (a watershed fanzine), an absolute MUST for Midwestcon and a person who perennially graces many fanzines with his presence. As he is a firm heterosexual, no one pays any attention to the fact that he has his arm around his friend James Beam at all conventions. The two are almost inseparable.

Bob claims to be of a venerable age, yet he has the looks and body of a man many years his junior. I can excuse his pretense of great age as a cheap way of acquiring the respect of the less-than-worldly-wise fan. Surely no man of his purported years can greet the dawn at every convention cheerfully without sleep. Tucker has been known to go to bed . . . but not to sleep.

Tucker was in fandom when politics were rife and hoaxes common; his death was reported many times starting in 1936. I believe, however, that these reports were no hoax. Certain documents lead me to the knowledge that Bob Tucker had taken leave of his native Heyworth, Illinois to go to the hills of Kentucky in 1936. Thanks to Manly Wade Wellman we know what sort of eldritch powers lay in the hills of Appalachia.

There were reports of rites in Clemons, Kentucky, and strange rites at Beastly's on the Bayou; the regular pilgrimages to the weird North Park Plaza, and the mystery of who sawed Courtney's Boat (which no man will speak of even today). None should be mentioned among civilized people. This is where I believe Tucker did indeed change from a mere mortal, giving up life as we know it for Fannish Power, Professional Strength and Eternal Youth — as long as he can keep that certain elixir of life (spirited — naturally) with him at all times.

I think he got the better of the deal. Just ask any femme fan.

But I can't claim this theory by my own poor merits. The clues were there all along — such as the name of his fanzine.

Semi-respectfully,

# ICON #1

Usher in Halloween with SFLIS!

The Science Fiction League of Iowa Students is holding its first Science Fiction Convention from October 31 to November 2. ICON #1 will offer only one trick, but many treats. Guest of Honor will be Roger Zelazny. There will be an All Hallows Eve Masquerade Ball, a Science Fiction and an Underground Film, an early and long Meet the Authors party, the everpresent panels and as much flowing spirits as you care to dam up. Also featured are a Huckster Room and an hour of entertainment called Duck's Breath Theater.

The place is the Ironmen Inn, Coralville Iowa. Cost; \$5 in advance, \$7 at the door. For info and registration, contact, and make checks payable to: Greg Frost, Box 510, Iowa City, Iowa, 52240. And remember, THE BIRD IS CRUEL!

Why did Poul Anderson endorse  
John Hospers, Libertarian Party  
candidate for Governor of California?  
TANSTAAFL, of course.

TANSTAAFL  
7820 Nordica  
Niles, Ill. 60648

## JONI STOPA FAN GUEST OF HONOR

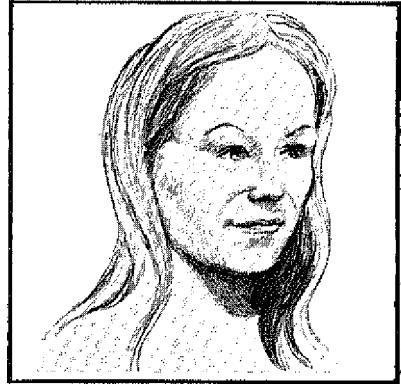

Jackie Franke

Joni Stopa has been in fandom since she was nine years old, which is a damned shame. Most healthy young women of that age have already found a husband and started a family instead of wasting their time on that classic Buck Rogers stuff. She entered the science fiction world during the era known to the historians as Seventh Fandom, which makes her a contemporary of Harlan Ellison, who was the founder of the Glorious Seventh. To this day she has no shame in finding her name linked with Mr. Ellison. Some say she secretly revels in it, that she is a secret reader and admirer of that well-loved pro.

Joni runs a ski lodge with the feeble assistance of a man who lives with her atop a terminal named Wilmot, Wisconsin. Of course, she would be out of business if the last ice age had not floated that far and in just that place. And in only a few hundred more years she will be out of business when the next glacier reduces Wilmot Mountain to a sand hill. To prepare for that certain event she has been learning to write science fiction in the drab tradition of her secret hero, and there are rumors around that she has already published stories under the pen name of Hugo Gernsbach.

In fandom Joni is best known for the spectacular displays of pelf and costumes exhibited at those historic events known as science fiction conventions. Frequently she herself will be on display along with her offspring and that aforementioned man who lives with her. When she is not participating in costume shows and masquerades she will be found behind the scenes directing them. This direction is simple and addressed to male and female contestants alike, "Take it off", she will cry. The judges out front will vote only for naked women, slaves in G-strings and belly dancers. If you don't have a belly, fake it but take it off.

Next year she is directing the masquerade at the Kansas City World Convention. All fandom will be plunged into war as a result. Joni the dictator has decreed that clothing will be prohibited.

— F.H.T. Pong

# COME ADVENTURING!

SEE YOU IN  
THE SECOND  
ISSUE, SUGAR

with  
**Nickelodeon,**  
the fanzine  
that  
explores  
uncharted  
territory.

**Intelligent,  
Irreverent,  
Audacious, & a  
little bit Mad.  
In issue no. 1:  
JAMES GUNN  
POUL ANDERSON  
PIERS ANTHONY  
BOB TUCKER  
R.A. LAFFERTY  
& fandom's only  
NUDE CENTERFOLDS**



The first-issue centerfold features the author of "Hung Like An Elephant," Steven Utley. Future Nickelodeons will contain two centerfolds—one male and one female—in each issue.

**NICKELODEON, 1131 WHITE, KANSAS CITY, MO 64126**

\$2.00 per copy

\$7.00 for a 1-year sub (4 issues)

\$13.00 for a 2-year sub (8 issues)

## ON SALE IN THE DEALERS ROOM



## BOB PASSOVOY TOASTMASTER



Bob was born in Knox, Indiana and has lived in Chicago since he was six. In sixth grade he discovered Norton and Heinlein; we all know what that sort of stuff leads to. He spent four years at the University of Illinois in Champaign, majoring in Microbiology and running around with a bunch of suspicious characters. Indeed, he died thrice in the course of duty as the above-mentioned group attempted to relieve the academic monotony by staging sword-fights and muggings in conspicuous places.

It was late in his Junior year when Bob decided that Micro was fine as a major but a dead loss as a career. The next year was spent in carousal and in picking up the prerequisites that allowed him to apply to medical schools. He entered the University of Maryland College of Medicine in 1968. During his holidays he occasionally visited his old cronies in Champaign, a vicious habit which usually got him into trouble and once stranded him waist-deep in cold water. Ask him about the Neil Street Massacre sometime.

In 1970 our hero was rudely yanked from the innocent ranks of closet fandom. A selection of Midwesterners snatched him from his ivied cloister and dragged him, kicking and screaming, to Noreascon. Three days later they returned him to school — scruffy, wild-eyed, suffering from con amnesia and Twonk's Disease — hopelessly addicted.

In 1971 Bob applied for clinical electives in Chicago so that he might attend midwestern conventions. He drove 1200 miles to spend eight hours at a Midwestcon. He spent his honeymoon bartending Champanacon 1. School policy required him to fly back to Baltimore for graduation (“... or we won't give you the diploma, kid, and remember yer not a doc until we say you are.”). The ceremonies were dull and endless but did coincide nicely with Disclave.

Over the years Bob has learned drinking from Bob Tucker, auctioning from John Trimble and the skill of doing-three-cons-in-five-weeks-while-remaining-rational-and-solvent from his wife. In 1974 he joined the Dorsai, rising to the rank of Farce Leader. A few people also know him as Medical Officer Kwak of the Klingon Diplomatic Corps.

Somewhere in there, in his secret identity as a physician at Rush-Presbyterian-St Luke's Hospital, Bob did three years of internship and residency. One must make some concessions to the mundane world, although it does tend to cramp the fannish lifestyle.

He is currently serving a two-year renal fellowship for his sins.

— Anne Passovoy

Tuck, Donald H., compiler. *The Encyclopedia of Science Fiction and Fantasy—A Bibliographic Survey of the Fields of Science Fiction, Fantasy, and Weird Fiction Through 1968; Volume 1: Who's Who, A-L*. Chicago: Advent, 1974. xii + 286 pp. \$20.00. LC 73-91828. ISBN 0-911682-20-1.

## MOST OF THE CRITICS LIKED IT—

The good work of establishing the foundations of science fiction bibliography and reference has been most effectively carried out up to the present moment by fan compilers and fan publishers. One of the best such works has been Donald H. Tuck's *A Handbook of Science Fiction and Fantasy*, self-published in Hobart, Tasmania. The most recent edition appeared in 1959 in two legal-size mimeographed paper-bound volumes.

Now the first volume of a new edition has appeared from Advent, calling itself *The Encyclopedia of Science Fiction and Fantasy* and deserving the title. It is a large hardcover book, handsomely bound and printed in double columns. More information is contained in the new first volume than in the entirety of the previous edition. . . .

This book is both a culmination and a first step. It is easily the broadest, most ambitious and most professionally conceived and executed work of science fiction scholarship and publishing that we have ever seen. It will necessarily become a standard library reference tool. It is an epitome of fan publishing, so significant that we wonder if Advent will be able to publish it and remain the same Sunday-afternoon publisher they have been.

At the same time, it is partial and incomplete. We have here only the first of three volumes, covering work only through 1968.

Even in its evident incompleteness, however, the *Encyclopedia* is a treasure. If you have an interest in sf, you will find it well worth its price. Buy it, or ask your library to buy it.

—Alexei and Cory Panshin, *The Magazine of Fantasy and Science Fiction*, December 1974

. . . In short the *Encyclopedia* is an awesome work of reference and enjoyment and it is the fruit of over 20 years labour by the compiler, made all the more remarkable because for all of that time he has lived in Tasmania, hardly the centre of the science fiction world.

There's simply no argument; anyone who takes their SF seriously (and most readers do) must have this book. Sell your shirt, pawn your watch, and buy it.

—Peter Weston, *Science Fiction Monthly*

. . . Like other Advent books, it is sturdily bound; the layout is the best I've seen from Advent. The *Encyclopedia* will be a necessity in almost all academic libraries and in medium- and large-sized high school and public libraries; scholars and collectors will want it too.

—Fred Lerner, *SFRA Newsletter*, No. 32

. . . Volume I, which I have seen in unbound pages, covers authors whose names begin with letters from A through L. Tuck calls it "Who's Who and Works." Volume II, scheduled for 1976, will cover M through Z and include an invaluable listing by title. . . . Volume III (1977) will have accounts of the SF and weird/fantasy magazines, including many borderliners, plus a paperback listing, plus a directory of pseudonyms, plus a breakdown of connected series and stories (such as the Heinlein "Future History" and Poul Anderson's vast tapestry), and a section on publishers, outstanding films, fanzines, and a big "et cetera."

. . . For novels, the encyclopedia begins with 1945, where [the Bleiler and Ditky "Checklist of Fantastic Literature"] stopped, and comes up through 1968. . . . It picks up some older books that the "Checklist" missed. . . . but it does not really dig into the past, unless a book has been reprinted in the 1945-1968 era. It includes many foreign-language editions.

Coverage of collections and anthologies is a good deal more complete, and will make the encyclopedia worth its price to many students and collectors. Tuck has ferreted out lists of the contents of 1550 one-author collections and 950 anthologies, some going back to the 1890's. The "Who's Who" includes paperback editions of major books; Volume III will list many more that aren't major. You also get, for many, many entries, capsule descriptions of a book, and other relevant data.

. . . If Tuck rests on his laurels—and after twenty years or more (much more) he could hardly be blamed—who will, who can carry on from 1968? He and Advent both ask for corrections and omissions. Somebody is going to try.

—P. Schuyler Miller, *Analog Science Fiction / Science Fact*, August 1974

Lika oumbärlig för varje SF-samlare som den samska bibliografin i början är ock *Donald J. Tucks* THE ENCYCLOPEDIA OF SCIENCE FICTION AND FANTASY THROUGH 1968 . . . . nu utkommen med sin första del av blivande tre. För austrafiske Don är en av världens absoluta superfans, och detta är hans magnum opus, en väldig vidareutveckling av hans många tidigare bibliografier.

—Roland Adlerberth, *Jules Verne-Magasinet*, 354

. . . Science fiction buffs already know this work well, by reputation at least, although not all may be fortunate enough to have seen a copy. First issued in 1954 in a duplicated edition entitled *A Handbook of Science Fiction*, revised and enlarged in 1959, it is a classic in its own time and is probably the most comprehensive reference work on science fiction and fantasy ever attempted. The earlier editions, now virtually unobtainable, are collectors' items.

—Mary Jo Walker, *American Reference Books Annual*, 1975

### —WITH ONE MAJOR EXCEPTION:

This is the book which . . . Alexei Panshin in *Fantasy and Science Fiction* [has] called a "treasure." Science-fiction has few enough of them; we could certainly use another. Let's have a look at it. . . . Avram Davidson, he will be happy to know, has had a number of his works translated, "especially into German." (Perhaps this is too obscure to pass without explanation: Davidson has quit two agents and three publishers that I know of for authorizing German editions of his work . . . Davidson for private and deeply-held reasons despises everything Germanic and has tried to publicize this as much as possible. Is this line stupid or malicious?) . . . . It is possible that this volume may have some bibliographic value; the tables of contents for anthologies and the bibliographies of the major writers appear, for instance, to be strikingly complete. The question still remains: who is it for? . . . It might be for the casual reader in the field who would appreciate some biographical information on writers

along with a list of their works, all of it available under one heading . . . but the biographies are so inaccurate as to render useless the other information provided. Bad information, where I come from, is worse than no information at all . . . . Where the *Encyclopedia* is not superficial it slides into fatuity. I just don't think that this is a good or helpful job . . . . I think that science-fiction deserves either nothing at all or something far better. . . . The pity is that this is a job which the field—which despite all my bitching I obviously love very much—needs desperately and which could and should have been done right . . . but Tuck has killed the market for at least twenty years. . . . And what, *pace* Panshin, are Charles E. Fritch or Martin Gardner doing in a book which excludes Wyman Guin and Miriam Allen De Ford?

—Barry Malzberg, *Science Fiction Review*, No. 12

[Entries for Guin and deFord are on pages 195 and 134-135, respectively.]

### WELL, WE CAN'T PLEASE EVERYBODY

Write to us for a descriptive price list of all our titles

## ADVENT:PUBLISHERS, INC.

Post Office Box A3228 — Chicago, Illinois 60690

## PROGRAM SCHEDULE

### FRIDAY

3:00 PM **COMPUTER GAMES** Churchill Suite

Games will run continuously throughout the con; a schedule will be posted near the terminal along with rules for specific games.

3:00 PM **MAGICK LANTERNE SHOW** Royal Court

The best of the last 20 years of Worldcons and other follies, captured on film -- including Aussiecon.

6:00 PM (possibly earlier) **ART SHOW OPENS** Cavalier West

**HUCKSTER ROOM OPENS** Derby A and B Rooms

8:00 PM **INTRODUCTION TO FANDOM PANEL** Royal Court

Joni Stopa, Al Frank and others; Ann Cass, moderator.

9:00 PM **RE-MAGICK LANTERNE SHOW** Royal Court

A rerun (so early in the season?) of the 3:00 PM slide program.

9:00 PM **ART SHOW AND HUCKSTER ROOMS CLOSE**

10:00 PM **MEET THE AUTHORS PARTY** Con Suite (3rd floor)

11:30 PM **FILM PROGRAM BEGINS** Royal Court

### SATURDAY

10:00 AM **ART SHOW OPENS** Cavalier West

**HUCKSTER ROOM OPENS** Derby A and B Rooms

10:00 AM **PRO PANEL: CAN YOU MAKE A LIVING WRITING SF?** Royal Court

Keith Laumer, Gordon Dickson, Mike Resnick, Phyllis Eisenstein; Jon Stopa, moderator.

11:00 AM **GREAT HOAXES OF THE WESTERN WORLD PANEL** Royal Court

Rusty Hevelin, Jack Chalker, Lou Tabakow; Bob Tucker, moderator.

1:00 PM **THE NEW SEARCH FOR EXTRATERRESTRIAL LIFE**

Dr. Eric Carlson, Senior Astronomer at the Adler Planetarium demonstrates the latest techniques and results.

2:45 PM **PRO PANEL: WHY IS A CLASSIC?** Royal Court

A. J. Budrys, George R. R. Martin, Lloyd Biggle, Gene Wolfe and others; Larry Propp, moderator.

4:00 PM **FANZINE WORKSHOP: A DISCUSSION AND DEMONSTRATION OF TECHNIQUES** Royal Court

Jackie Franke, Bill Bowers and others; Ben Solon, moderator.

6:00 PM **ART SHOW AND HUCKSTER ROOMS CLOSE**

7:00 PM **MASQUERADE PRE-JUDGING** Churchill Suite

Make sure you've read the rules ver-r-r-ry, ver-r-r-ry carefully.

8:00 PM **MASQUERADE** Royal Court

The famed Channukah Chailanders will pipe all to the gathering; there will be a cash bar to accommodate those whose mouths go dry at the thought of skimpy costumes.

9:00 PM **ART AUCTION, PART 1** Royal Court

11:30 PM **FILMS BEGIN** Royal Court

**CON SUITE OPENS** (3rd floor)

## SUNDAY

10:00 AM HUCKSTER ROOM OPENS Derby A and B Rooms

10:00 AM COLLECTORS AND COLLECTING PANEL Cavalier East Room  
Robert Weinberg, Alex Eisenstein, Ed Wood and others; John Guidry, moderator.

11:00 AM BRUNCH (OR BREAKFAST) BUFFET Royal Court  
Guest-of-Honor speeches, official presentation to George R. R. Martin of his Aussiecon Hugo, a whole bunch of other diplomatic formalities and the Art Awards.

1:30 PM ART AUCTION, PART 2 Royal Court or Cavalier West  
The size of the remaining art auction fanatic crowd will determine the location of the closing auction.

There will in all likelihood be a deadhead party.

---

## MOVIES

Note: Times shown are running times. A blackboard outside the film room will display the time of the next film – and what it is, of course.

### FRIDAY

**The Fatal Glass of Beer** 20 min.  
W.C. Fields

**Dr. Jekyll and Mr. Hyde** 58 min.  
Silent version

**Jet Jackson** 35 min.  
O! Jet was known in some parts of the country as Captain Midnight

**Aqua Velva commercial** 1 min.  
Starring the Lone Ranger

**Nosferatu** 30 min.  
The original silent Dracula prototype, starring Max Schreck

**Sail a Crooked Ship** 90 min.  
A moderately obscure 1959 Ernie Kovacs feature

**Ersatz** 10 min.  
Animated short

**Their First Mistake** 20 min.  
Laurel and Hardy short

**The Twonky** 75 min.  
Starring Hans Conreid and a TV console from the future

**Pizza Roll commercial** 1 min.  
Starring the Lone Ranger

### SATURDAY

**Man from A.U.N.T.I.E** 20 min.  
Animated short on out-of-this-world insurance selling

**Captain Mom** 15 min.

Another animated short  
**Japanese soap commercial** 1 min.  
Try it, you'll like it

**Gene Autrey and the Phantom Empire** 90 min.

Gene's infamous SF feature, back by popular request  
**Mars and Beyond** 30 min.

Disney's animated feature about Man Conquering the Planets – still one of his best

**Metropolis** 80 min.  
The silent classic

**Omega** 15 min.  
Animated short

**Writer's Life** 35 min.  
An interview with Ray Bradbury

## KNOW YOUR DORSAI IRREGULAR

For the information of the blissfully uninformed, those black-bereted, green-uniformed ruffians peering at you suspiciously through bloodshot eyes are for real. They're the Dorsai Irregulars, an All-Fan, Non-Profit Security Force contracted by the Con to lurk, smirk, pry and in general keep things from getting dull.

Who are they? One answer pegs them as a group of fans who got together to form a non-profit organization whose motives are: (A) To assist con committees by relieving them of a major headache — recruiting, scheduling and riding herd on a Security Force; (B) To stretch their own con dollars as far as possible.

As they are one of the first fan organizations to charge for their services, it seemed only natural for them to adopt for personas the mercenary characters of the Dorsai. (You are familiar with Gordon R. Dickson's *Chylde Cycle*, aren't you? If not, advance to Go and read *Necromancer*, *Tactics of Mistake*, *Soldier Ask Not* and *Dorsai!*).

Another explanation portrays them as late immigrants to Dorsai who never quite got the hang of blending with the military crispness of the forces already in residence on that planet. Claiming Mongol ancestry with heavy Irish influence (stemming mostly from the Tullamore region of the Irish Republic), they were quickly dubbed by the predominantly Welsh-Scottish citizenry rowdy, boorish, unorthodox and . . . well . . . irregular.

The specialty of the House(hold) is Infiltration and Demolition; they are also adept at petty theft, extortion and piracy. While the latter traits are not particularly conducive to contractual formalities, they nevertheless make the Irregulars eminently qualified to serve as guards (set a poacher to catch a poacher, what?). They also operate on two planes of existence — theirs, and everyone else's.

Take your pick.

(Further information is available from Dorsai Irregulars, Ltd., PO Box 1821, Ann Arbor, MI 48103).

---

September 22, 1975

## AN APPRECIATION OF LEWIS J. GRANT, JR.

Lewis Grant was one of the very few people I have known who could rightly be called a "Renaissance Man," intellectually if not physically. Wherever a conversation might turn — science and technology, science fiction, politics and public affairs — he would nearly always be well-informed and full of fascinating opinions. Those who came to know Lewie were usually surprised to discover that he did not have an advanced degree, or indeed any degree at all. That he was largely self-educated may even be why he never fell into the trap of becoming a narrow specialist. Nor was his encyclopedic knowledge merely a collection of miscellaneous tidbits: he had a very strong sense of the interrelatedness of everything, and could draw together facts from widely scattered fields and integrate them in surprising ways. It may have been his philosophic sense of the wholeness of knowledge and life that enabled him to cheerfully endure the physical defects that eventually took him from us. He always faced life with a smile and a joke — he was famous for atrocious puns at which we groaned more in envy than in pain. Lewie's life was short, but he put more into it, of accomplishment, friendship, and human decency, than most of us put into twice the time.

George W. Price

(Windycon is pleased and proud to present the Lewis J. Grant, Jr. Memorial Award, which carries a \$25 cash prize, for the Best-in-Show artwork.)

WINDYCON 2  
 Back Issue "Sale"

EDITOR  
**BILL BOWERS**

COLUMNISTS  
**POUL ANDERSON**  
**PIERS ANTHONY**  
**GREG BENFORD**  
**MIKE GORRA**  
**ROBERT A.W. LOWNOES**  
**ANDREW J OFFUTT**  
**JODIE OFFUTT**  
**BOB TUCKER**  
**TED WHITE**  
**SUSAN WOOD**

Associate Editors: DAVE LOCKE;  
 STEPHEN E. FABIAN; MICHAEL GLICKSOHN



# Outworlds

.....THE ECLECTIC FANZINE.....

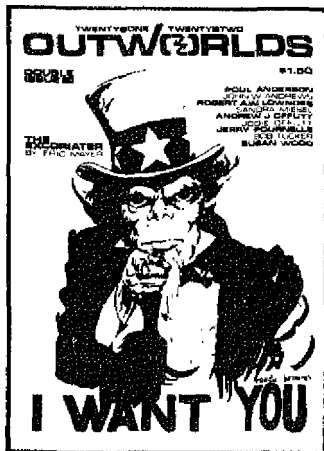

<u>Issues Available</u>	<u>HERE</u>	<u>by Mail</u>
OUTWORLDS #19	75¢	\$1.00
OUTWORLDS #20	75¢	\$1.00
OUTWORLDS #21/22*	\$1.25	\$1.50
OUTWORLDS #23	\$1.25	\$1.50
OUTWORLDS #24	75¢	\$1.00
OUTWORLDS #25	75¢	\$1.00

Subscriptions: Four Issues for \$4.00

\* Winner of Fanzine Activity Achievement Award: Best Single Issue of 1974

# This mimeograph thinks it's a printing press.

Give it a stencil from our famous Model 590 stencil maker and it prints photos,

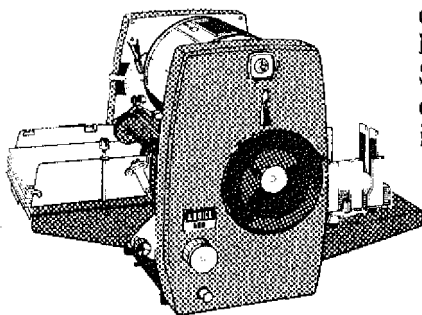

existing forms, price lists, letterheads . . . or any new material you clip, paste or create. Copies come up clear, sharp, professional-like . . . and fast. Come in. See for yourself what it can do. And how easy it does it.

**ABDICK®**

USED - TO MGC  
DE LEAVE FOR MGC.  
TUES - CONTACT + ENVELOPE STUFFING AT MADISON'S  
MAY - CALL LARRY MANU: KAWAIE DORAI BLIND.  
SAT - APPLS - SAMOBAI GEAR TO DENIS

THUR - HOUSE  
FRI - KADVAUR STUBB

USED - TRUCK SHOP W. DEE - CALL LARRY MANU: KAWAIE DORAI BLIND  
TUES - TILLS TO MITCH + WOOZ - BINDER - CALL MADISON'S

A.B. Dick is providing the Mimeograph used in the Fanzine Workshop